

ML-SR-35VL



Up lighted Road Stud

KEY FEATURES

- Road stud specially developed to illuminate historic areas and pedestrian zones
- Ideal for zones where it's necessary to project vertical lighting
- Rising from road surface of 17mm
- High brightness during day and night
- 360° Lighting
- Possibility of connection of **N** elements
- Wired system that can be powered by electric or solar energy
- Low power consumption
- Internal prismatic system
- Many led's color options for all kind of applications
- Easy maintenance

MODES OF OPERATION

- Always On
- *Other modes of operation like flashing or sequential are available with external controller

LED'S CONFIGURATION

- Up light
- Up light + Side light

ELECTRICAL FEATURES

Power Supply	12 V DC or 24V DC
Current Consumption	Up Light: 140 mA Side Light: 160mA
Power Cable	Brown Wire (+) Blue Wire (-)
Working Temperature	-25 °C to +85°C

OPTICAL FEATURES

- Led Quantity**
14 Led's
(Up to 16 optional led's may be added to the sides)
- Led Type**
5mm
- Led Colors**
White, Warm White, Red, Amber, Green, Blue
- Viewing Angle**
15°

MECHANICAL FEATURES

- Material**
Aluminum and Polycarbonate
- Mechanical Resistance**
18 Tons
- Weight**
1 Kg
- Protection Index**
IP68, IK10
- Dimensions**
Ø145 x 89 mm

ML-SR-35VL



DIMENSIONS (mm)

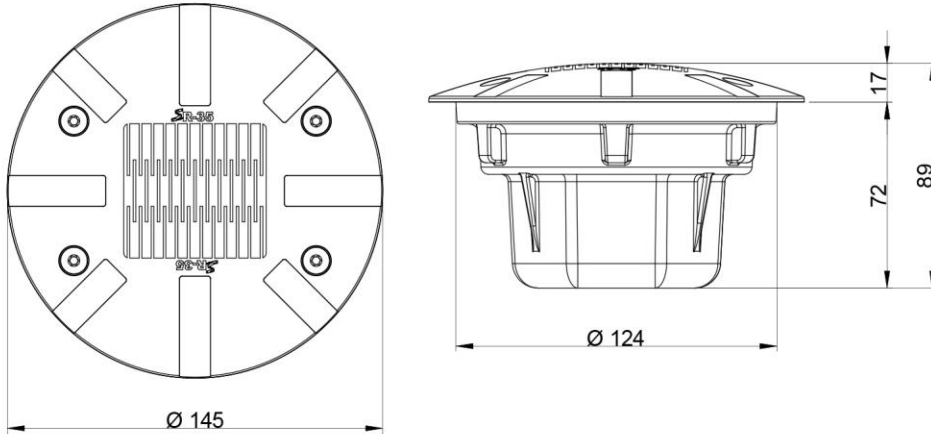

INSTALLATION PROCEDURE



To do the installation Personal Protective Equipment must be worn during all process.

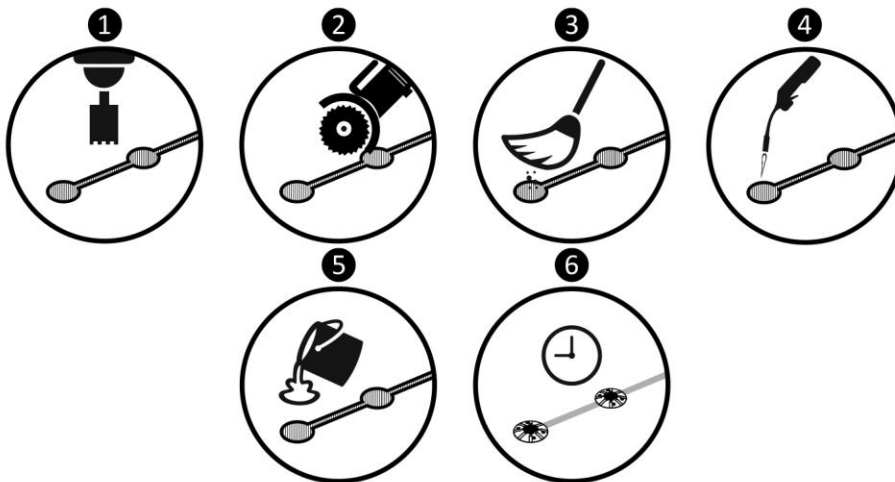

❶ After deciding the location where the stud will be installed, drill a hole having a minimum diameter of 130 mm and 80 mm deep.

❷ Using a disk cutter, open a connection between the holes with 15mm width and 60mm depth.

❸ Brush any debris or dust from the hole resulting from drilling.

❹ Dry the hole with a blowtorch to remove any moisture that may compromise the adhesion and effectiveness of the glue.

❺ Pour ±2Kg of glue **Sikadur 42 SP** in the hole and insert the stud checking that the led's are facing the right way. Remove any excess remaining of glue.

❻ The glue drying time may change depending on weather conditions. Consult the glue data sheet for more information.

Changing or not fulfillment of the described installation process can result in suspension of warranty.